



## HAMMERSCHRAUBE

## HAMMER HEAD SCREW

<b>Ausführung</b>	Nut 8, Stahl / Edelstahl	<b>Model</b>	Slot 8, steel / stainless steel
<b>Beschreibung</b>	Befestigungselement für Aluminiumprofile, bricht die Eloxalschicht auf und schafft eine sichere, elektrisch  leitfähige Verbindung	<b>Description</b>	To fasten components to profiles, breaks the anodized coat of the profile - thus ensuring a safe, electrically  conductive connection
<b>Material</b>	Stahl, verzinkt / Edelstahl 1.4401	<b>Material</b>	Zinc plated steel / stainless steel SS316
<b>Liefereinheit</b>	100 Stück	<b>Pack Quantity</b>	100 pieces
<b>Extras</b>	Drehhilfe: Polyamid-Fleckbeschichtung auf Anfrage Oberfläche: mit Trocken-Gleitfilm, Zink-Nickel- oder Zink-Lamellen-Überzug auf Anfrage	<b>Specials</b>	Turning help: Polyamide thread locking dot on request Surface: With dry film lubrication, zinc-nickel plated or with zinc lamellar plating on request
<b>Hinweis</b>	passende Flanschnutter siehe Seite 301 * bestehend aus Hammermutter mit geklebtem Gewindestück	<b>Tip</b>	Compatible flange nut see page 301 *Made of hammer nut with glued threaded rod

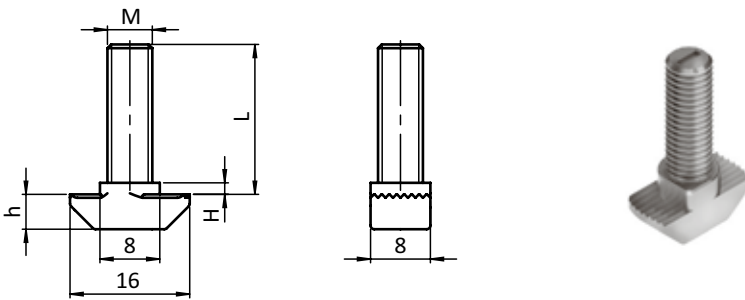

Hammerschraube Hammer Head Screw	H [mm]	Größe M × L [mm] Size M × L [mm]	Gewicht [g] Weight [g]	Profil Profile	Teil-Nr. Part #
Stahl <i>Steel</i>	1.5	M6 × 16	5.3	B	096HK0815M0616
	1.5	M6 × 20	6.2	B	096HK0815M0620
	1.5	M6 × 25	7.0	B	096HK0815M0625
	1.5	*M6 × 30	8.6	B	096HK0815M0630
	1.5	*M6 × 40	10.4	B	096HK0815M0640
	1.5	M6 × 60	13.4	B	096HK0815M0660
	1.5	M8 × 20	9.0	B	096HK0815M0820
	1.5	M8 × 25	10.6	B	096HK0815M0825
	1.5	M8 × 30	12.1	B	096HK0815M0830
	3.0	M6 × 20	5.6	I	096HK0830M0620
	3.0	M6 × 25	6.4	I	096HK0830M0625
	3.0	*M6 × 30	8.0	I	096HK0830M0630
	3.0	*M6 × 40	9.8	I	096HK0830M0640
	3.0	*M6 × 60	12.8	I	096HK0830M0660
	3.0	M8 × 20	9.0	I	096HK0830M0820
	3.0	M8 × 25	10.6	I	096HK0830M0825
3.0	M8 × 30	12.1	I	096HK0830M0830	
3.0	M8 × 40	20.5	I	096HK0830M0840	
Edelstahl <i>Stainless steel</i>	1.5	*M6 × 20	7.6	B	096HK0815M0620E
	1.5	*M6 × 25	8.4	B	096HK0815M0625E
	1.5	*M6 × 30	9.4	B	096HK0815M0630E
	1.5	*M6 × 40	11.2	B	096HK0815M0640E
	1.5	*M6 × 60	14.4	B	096HK0815M0660E